

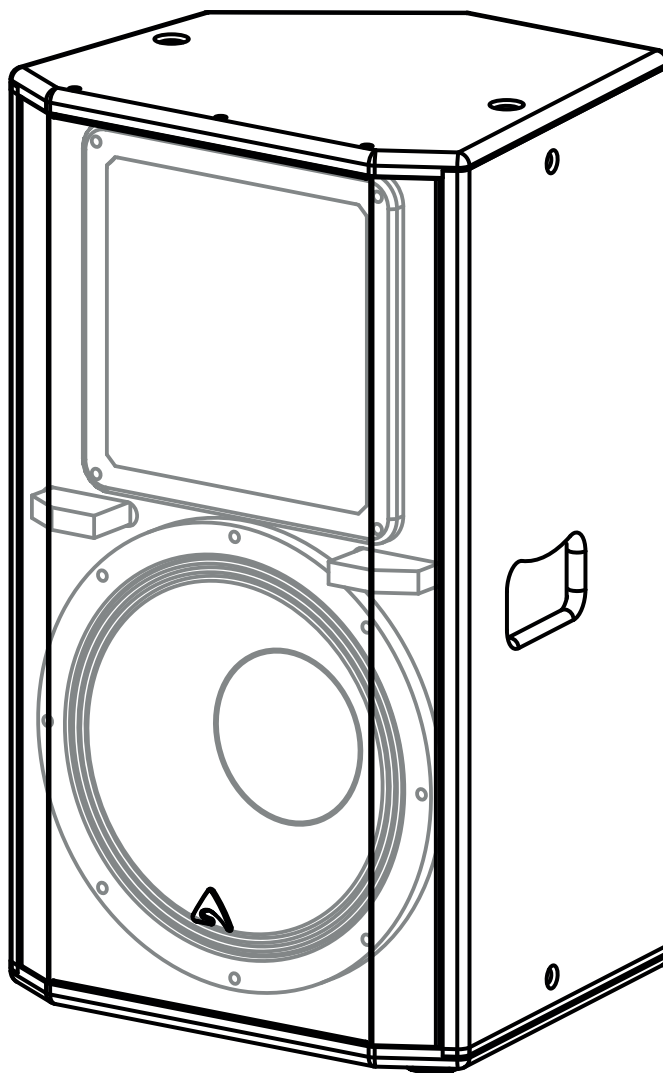

ED120A

active point source loudspeaker



USER MANUAL

revision 2023-09-01





IMPORTANT SAFETY INSTRUCTIONS

Watch for these symbols:



The lightning flash with arrowhead symbol within an equilateral triangle is intended to alert the user to the presence of uninsulated “dangerous voltage” within the product’s enclosure, that may be of sufficient magnitude to constitute a risk of electric shock to persons.



The exclamation point within an equilateral triangle is intended to alert the user to the presence of important operating and maintenance (servicing) instructions in the literature accompanying the appliance.

1. Read these instructions.
2. Keep these instructions.
3. Heed all warnings.
4. Follow all instructions.
5. Do not use this apparatus near water.
6. Clean only with dry cloth.
7. Do not block any ventilation openings. Install in accordance with the manufacturer’s instructions.
8. Do not install near any heat sources such as radiators, heat registers, stoves, or other apparatus (including amplifiers) that produce heat.
9. Do not defeat the safety purpose of the polarized or grounding-type plug. A polarized plug has two blades with one wider than the other. A grounding-type plug has two blades and a third grounding prong. The wide blade or the third prong are provided for your safety. If the provided plug does not fit into your outlet, consult an electrician for replacement of the obsolete outlet.
10. Protect the power cord from being walked on or pinched, particularly at plugs, convenience receptacles, and the point where they exit from the apparatus.
11. Only use attachments/accessories specified by the manufacturer.
12. Use only with the cart, stand, tripod, bracket, or table specified by the manufacturer, or sold with the apparatus. When a cart is used, use caution when moving the cart/apparatus combination to avoid injury from tip-over.
13. Unplug this apparatus during lightning storms or when unused for long periods of time.
14. Refer all servicing to qualified service personnel. Servicing is required when the apparatus has been damaged in any way, such as power supply cord or plug is damaged, liquid has been spilled or objects have fallen into the apparatus, the apparatus has been exposed to rain or moisture, does not operate normally, or has been dropped.
15. Warning: to reduce the risk of fire or electric shock, do not expose this apparatus to rain or moisture.
16. Do not expose this equipment to dripping or splashing and ensure that no objects filled with liquids, such as vases, are placed on the equipment.
17. To completely disconnect this apparatus from the ac mains, disconnect the power supply cord plug from the ac receptacle.
18. The mains plug of the power supply cord shall remain readily operable.
19. This apparatus contains potentially lethal voltages. To prevent electric shock or hazard, do not remove the chassis, input module or ac input covers. No user serviceable parts inside. Refer servicing to qualified service personnel.
20. The loudspeakers covered by this manual are not intended for high moisture outdoor environments. Moisture can damage the speaker cone and surround and cause corrosion of electrical contacts and metal parts. Avoid exposing the speakers to direct moisture.
21. Keep loudspeakers out of extended or intense direct sunlight. The driver suspension will prematurely dry out and finished surfaces may be degraded by long-term exposure to intense ultra-violet (UV) light.
22. The loudspeakers can generate considerable energy. When placed on a slippery surface such as polished wood or linoleum, the speaker may move due to its acoustical energy output.
23. Precautions should be taken to assure that the speaker does not fall off a stage or table on which it is placed.
24. The loudspeakers are easily capable of generating sound pressure levels (SPL) sufficient to cause permanent hearing damage to performers, production crew and audience members. Caution should be taken to avoid prolonged exposure to SPL in excess of 90 dB.

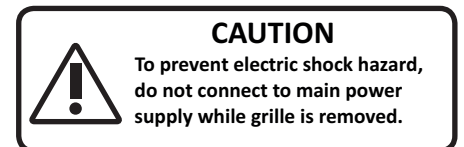

This marking shown on the product or its literature, indicates that it should not be disposed with other household wastes at the end of its working life. To prevent possible harm to the environment or human health from uncontrolled waste disposal, please separate this from other types of wastes and recycle it responsibly to promote the sustainable reuse of material resources. Household users should contact either the retailer where they purchased this product, or their local government office, for details of where and how they can take this item for environmentally safe recycling. Business users should contact their supplier and check the terms and conditions of the purchase contract. This product should not be mixed with other commercial wastes for disposal.



FEDERAL COMMUNICATIONS COMMISSION (FCC) STATEMENT

This equipment has been tested and found to comply with the limits for a Class A digital device, pursuant to part 15 of the FCC Rules. These limits are designed to provide reasonable protection against harmful interference when the equipment is operated in a commercial environment. This equipment generates, uses, and can radiate radio frequency energy and, if not installed and used in accordance with the instruction manual, may cause harmful interference to radio communications.

Operation of this equipment in a residential area is likely to cause harmful interference in which case the user will be required to correct the interference at their own expense.

This device complies with Part 15 of the FCC rules. Operation is subject to the following two conditions:

- (1) this device may not cause harmful interference, and
- (2) this device must accept any interference received, including interference that may cause undesired operation.

DECLARATION OF CONFORMITY

C E The product is in compliance with:
EMC Directive 2014/30/EU, LVD Directive 2014/35/EU, RoHS Directive 2011/65/EU and 2015/863/EU, WEEE Directive 2012/19/EU.

EN 55032 (CISPR 32) STATEMENT

Warning: This equipment is compliant with Class A of CISPR 32. In a residential environment this equipment may cause radio interference. Under the EM disturbance, the ratio of signal-noise will be changed above 10 dB.

UK CA The product is in compliance with:
S.I. 2016/1091 Electromagnetic Compatibility Regulations 2016, S.I. 2016/1101 Electrical Equipment (Safety) Regulations 2016, S.I. 2012/3032 The Restriction of the Use of Certain Hazardous Substances in Electrical and Electronic Equipment Regulations 2012.

CISPR 32 STATEMENT

Warning: This equipment is compliant with Class A of CISPR 32. In a residential environment this equipment may cause radio interference. Under the EM disturbance, the ratio of signal-noise will be changed above 10 dB.

LIMITED WARRANTY

Proel warrants all materials, workmanship and proper operation of this product for a period of two years from the original date of purchase. If any defects are found in the materials or workmanship or if the product fails to function properly during the applicable warranty period, the owner should inform about these defects the dealer or the distributor, providing receipt or invoice of date of purchase and defect detailed description. This warranty does not extend to damage resulting from improper installation, misuse, neglect or abuse. Proel S.p.A. will verify damage on returned units, and when the unit has been properly used and warranty is still valid, then the unit will be replaced or repaired. Proel S.p.A. is not responsible for any "direct damage" or "indirect damage" caused by product defectiveness.

- This unit package has been submitted to ISTA 1A integrity tests. We suggest you control the unit conditions immediately after unpacking it.
- If any damage is found, immediately advise the dealer. Keep all unit packaging parts to allow inspection.
- Proel is not responsible for any damage that occurs during shipment.
- Products are sold "delivered ex warehouse" and shipment is at charge and risk of the buyer.
- Possible damages to unit should be immediately notified to forwarder. Each complaint for package tampered with should be done within eight days from product receipt.

CONDITIONS OF USE

Proel do not accept any liability for damage caused to third parties due to improper installation, use of non-original spare parts, lack of maintenance, tampering or improper use of this product, including disregard of acceptable and applicable safety standards. Proel strongly recommends that this loudspeaker cabinet be suspended taking into consideration all current National, Federal, State and Local regulations. The product must be installed by qualified personal. Please contact the manufacturer for further information.



INDEX

INTRODUCTION	4
TECHNICAL SPECIFICATION	4
MECHANICAL DRAWING	5
OPTIONAL ACCESSORIES	5
SPARE PARTS	5
I/O AND CONTROL OPERATIONS	6
MAINS IN.	6
MAINS OUT.	6
INPUT	6
LINK	6

ON	6
SIGN/LIMIT	6
GND LIFT	6
NETWORK IN/OUT	6
TERMINATE	6
PRESET BUTTON	7
PRONET AX	8
HORN ORIENTATION	10
KPTED120B WALL or TRUSS MOUNTING	11

INTRODUCTION

ED point source systems are designed for indoor and outdoor sound reinforcement applications ranging from clubs, bars and restaurants to theatres, live music venues, houses of worship and theme environments. The ED120A is a powered loudspeaker system able to deliver consistently repeatable performance due to the PROEL CORE digital signal processing and the integrated Class D amplifier module.

The ED120A consists of an 12" LF drive unit and a 1.4" HF compression driver loaded by an asymmetric HF horn in a compact enclosure, designed for many multi-purpose sound reinforcement activities. The asymmetric HF coverage pattern, varying from 100° horizontal in the lower part of the horn for more effective near field coverage, and narrowing to 60° horizontal at the top of the horn for more focused coverage in the far field. The result is more accurate coverage of a typical auditorium than is possible with a fixed horizontal coverage device. The HF horn is also rotatable through 90° by simply removing four screws and realigning the horn, so that coverage can also be optimised for stage monitor use. This rotatable horn feature also makes it possible to maintain the ideal coverage pattern when the cabinet is installed in a horizontal (landscape) orientation. Its asymmetric dispersion pattern provides optimal coverage of typical rectangular venues, with wider dispersion at the front and narrower dispersion at the rear.

This versatile loudspeaker can also be used as a low profile stage monitor with its 35° tapered side, and in this situation the HF horn can be rotated to maintain the best coverage pattern for performers both near to and further away from the monitor. ED120A cabinet is an unobtrusive and compact format designed for a multitude of near field applications such as theatre under-balcony fill, stage front fill, delay speaker, bar and restaurant audio, and discreet stage monitor. A pole mount socket make this a very versatile loudspeaker in both portable and permanently installed applications.

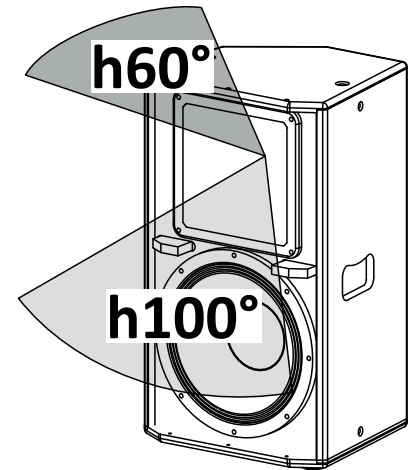

TECHNICAL SPECIFICATION

SYSTEM

System's Acoustic Principle	Two-way Vented Enclosure Asymmetric Dispersion
Frequency response	65 Hz – 17 kHz (-6dB Processed)
Horizontal Coverage Angle	60 to 100° (-6 dB)
Vertical Coverage Angle	60° (-6 dB)
Maximum Peak SPL @ 1m	132 dB

TRANSDUCERS

Low frequency transducer	12" (300 mm), 3" (75 mm) ISV aluminium voice coil, 4Ω
High frequency transducer	1.4" (35.5 mm) compression driver, 2.4" (60 mm) aluminium voice coil, Titanium diaphragm, 8Ω

ELECTRICAL

Input Impedance	20 kΩ balanced
Input Sensitivity	+4 dBu / 1.25 V
Signal Processing	CORE2 processing, 40bit floating point SHARC DSP, 24 bit AD/DA converters
Direct access Controls	4 Presets: Standard, Low Cut, Monitor, User. Network Termination, GND Link

Remote Controls	PRONET AX control software
Network protocol	CANBUS
Amplifier Type	Class D amplifier with SMPS
Output Power	900W + 300W
Mains Voltage Range (Vac)	220-240V~ or 100-120V~ ±10% 50/60 Hz
Consumption*	575 W (nominal) 1200 W (max)
IN / OUT Connectors	Neutrik XLR-M / XLR-F
IN / OUT Network Connectors	ETHERCON® (NE8FAV)
Mains Input/Link Connectors	PowerCon® (NAC3MPXXA+NAC3MPXXB)
Cooling	Variable speed DC fan

ENCLOSURE & CONSTRUCTION

Width	360 mm (14.2")
Height	610 mm (24")
Depth	310 mm (12.2")
Taper angle	Stage Monitor: 35° - Frontfill: 7.5°
Enclosure Material	15mm, reinforced phenolic birch
Paint	High resistance, black or white water based paint
Flying System	M10 / M6 flying points or dedicated metal brackets
Net Weight	19 Kg (41.8 lbs)

* Nominal consumption is measured with pink noise with a crest factor of 12 dB, this can be considered a standard music program.



MECHANICAL DRAWING

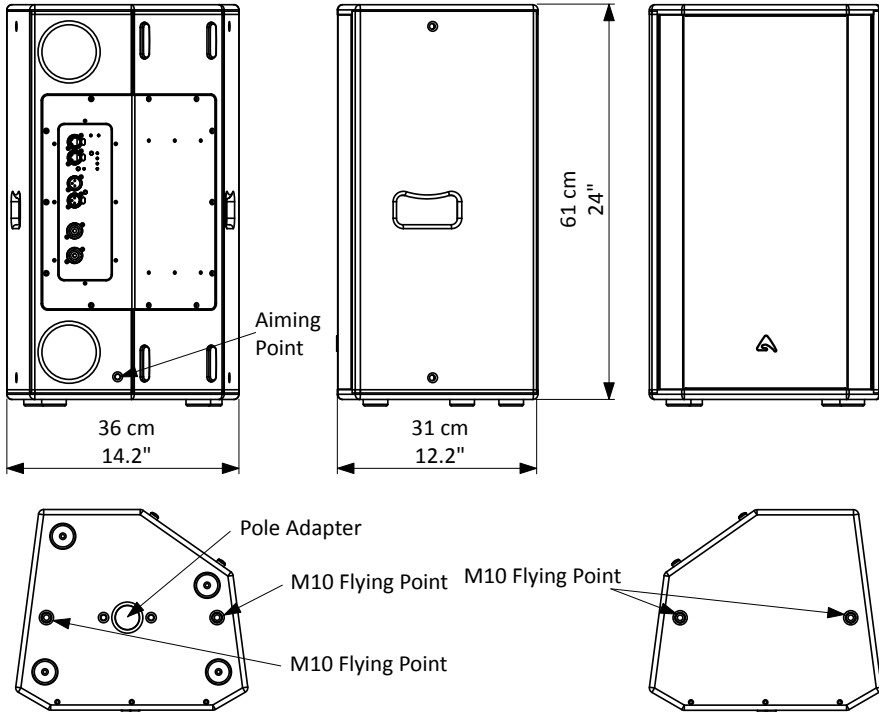

INSTRUCTION FOR ROTATING THE HORN
1) Remove the speaker grid unscrewing the six screws indicated below.

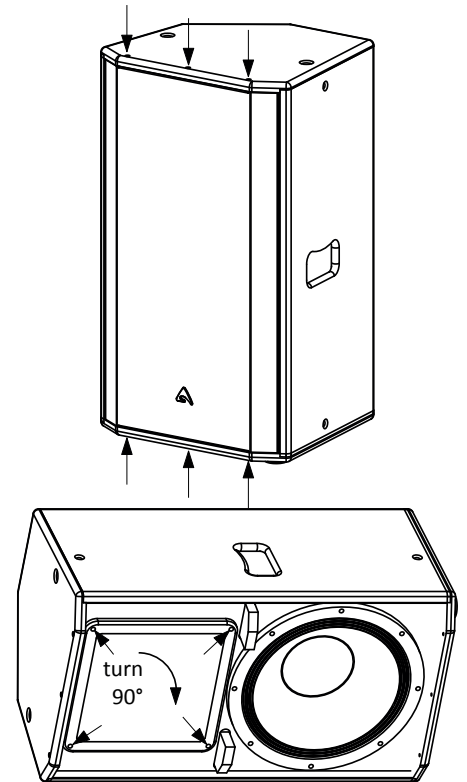

2) Unscrew the 4 screws fixing the horn and rotate the horn by 90°.

OPTIONAL ACCESSORIES

KPTED120B Wall or Truss Mounting "C" bracket.

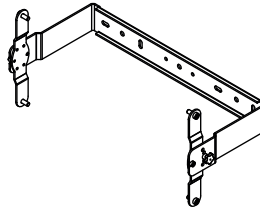

PLH300 Ø 48-51mm truss tube aluminium coupler with M12 x 50 built-in bolt and fastening nut.



NAC3FCA Neutrik Powercon® BLUE PLUG

NAC3FCB Neutrik Powercon® WHITE PLUG

NE8MCB Neutrik Ethercon PLUG

see <http://www.axiomproaudio.com/> for detailed description and other available accessories.

NC3MXXBAG Neutrik XLR-M

NC3FXXBAG Neutrik XLR-F

USB2CAN-D PRONET network converter

SPARE PARTS

NAC3MPA Neutrik Powercon® BLUE SOCKET

NAC3MPB Neutrik Powercon® WHITE SOCKET

91AMDED120A Power amplifier module with mechanical assembly

98ED120WZ4 12" woofer - 3" VC - 4 ohm

98DRI2065 1.4" - 2.4" VC compression driver - 8 ohm

98MBN2065 titanium diaphragm for 1.4" driver



I/O AND CONTROL OPERATIONS

MAINS IN

Powercon® NAC3FCA power input connector (blue). To switch the amplifier on, insert the Powercon® connector and turn it clockwise into the ON position. To switch the amplifier off, pull back the switch on the connector and turn it counter-clockwise into the POWER OFF position.

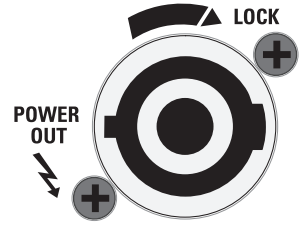

MAINS OUT

Powercon® NAC3FCB power output connector (grey). This is connected in parallel with the MAINS ~ / IN. The maximum load applicable depends on the mains voltage. With 230V~ we suggest to link a maximum of 5 ED120A loudspeakers, with 120V~ we suggest to link a maximum of 3 ED120A loudspeakers.

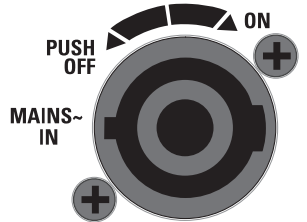

WARNING! In the case of product failure or fuse replacement, disconnect the unit completely from the mains power. The power cable must only be connected to a socket corresponding to the specifications indicated on the amplifier unit.



The power supply must be protected by a suitably rated thermo-magnetic breaker. Preferably use a suitable switch to power on the whole audio system leaving the Powercon® always connected to each speaker, this simple trick extend the life of the Powercon® connectors.

INPUT

Audio signal input with locking XLR connector. It has a fully electronically balanced circuitry including AD conversion for the best S/N ratio and input headroom.

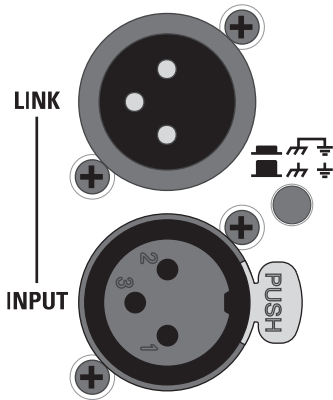

LINK

A direct connection from the input connector to link other speakers with same audio signal.

ON

This LED indicates power on status.

SIGN/LIMIT

This LED lights in green to indicate the presence of the signal and lights in red when an internal limiter reduces the input level.

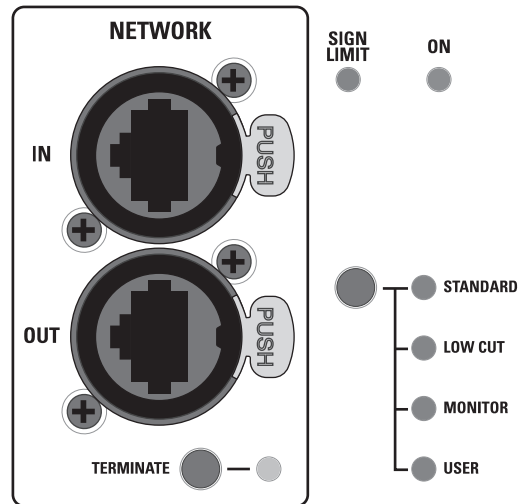

GND LIFT

This switch lift the ground of the balanced audio inputs from the earth-ground of the module.

NETWORK IN/OUT

These are a standard RJ45 CAT5 connectors (with optional NEUTRIK NE8MC RJ45 cable connector carrier), used for PRONET AX network transmission of remote control data over long distance or multiple unit applications.

TERMINATE

In a PRONET AX network the last loudspeaker device must be terminated (with an inner load resistance) especially in a long run cabling: press this switch if you want to terminate the unit.



PRESET BUTTON

This button has two functions:

1) Pressing it while powering on the unit:

ID ASSIGN the internal DSP assigns a new ID to the unit for the PRONET AX remote control operation. Each loudspeaker must have a unique ID to be visible in the PRONET network. When you assign a new ID, all the other loudspeakers with the ID already assigned must be ON and connected to the network.

2) Pressing it with the unit ON you can select the DSP PRESET. The selected PRESET is indicated by the corresponding LED:

STANDARD Suited for a typical use of a standalone loudspeaker for any sound reinforcement situation.

LOW CUT This PRESET is the same of the previous with an high pass filter (110Hz @ 48 dB/oct.) to use the loudspeaker in combination with a subwoofer.

MONITOR Suited for the use of the system as a stage monitor, in this preset the deep lows are attenuated in order to compensate the floor position, the mid-low frequencies are enhanced for a better presence and the mid-high frequencies are reduced for an improved feedback rejection.

USER This LED lights when the USER PRESET is loaded. This preset corresponds to USER MEMORY no. 1 of the DSP and, as a factory setting, it's the same to STANDARD. If you want to modify it, you have to connect the unit to a PC, edit the parameters with PRONET AX software and save the PRESET into USER MEMORY no. 1.

Note: see also the PRONET example further on this manual.

ED120A - PRESET RESPONSE

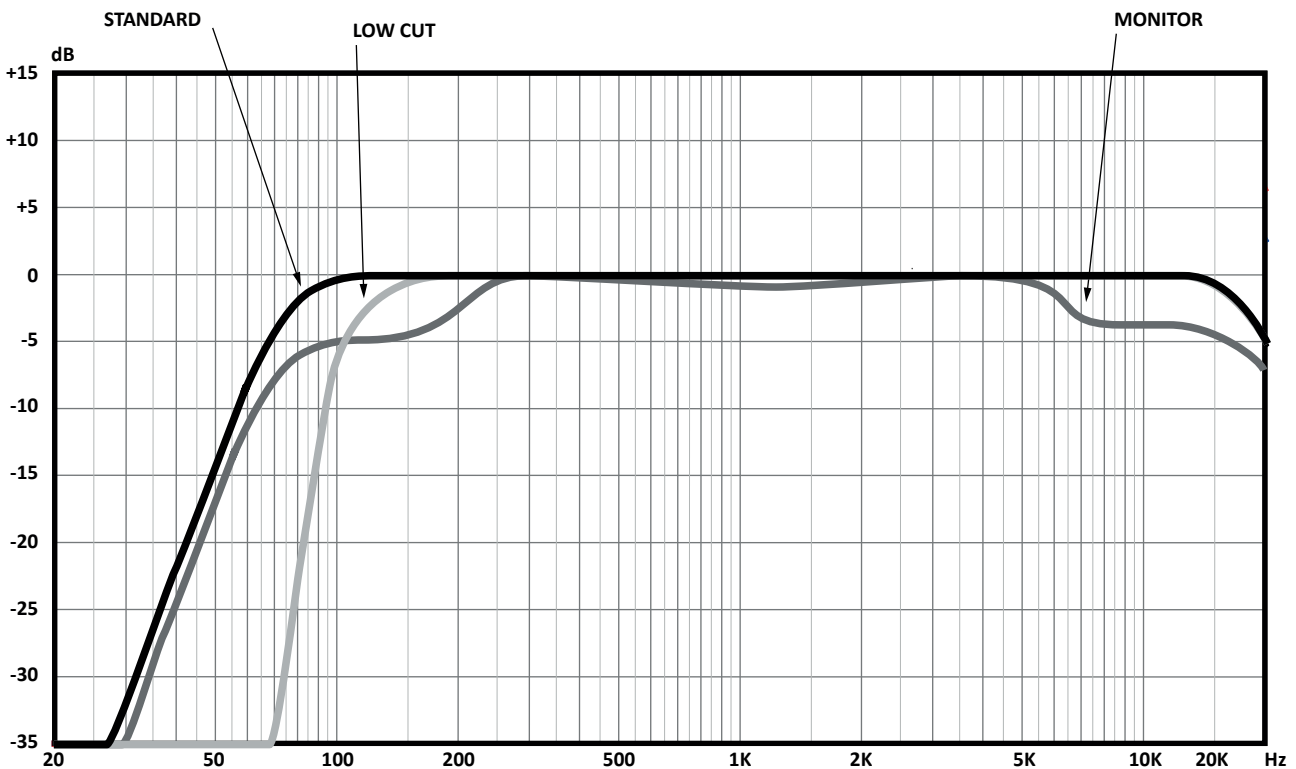



PRONET AX

PRONET AX software has been developed in collaboration with sound engineers and sound designers, in order to offer an “easy-to-use” tool to setup and manage your audio system. With PRONET AX you can visualize signal levels, monitor internal status and edit all the parameters of each connected device.

Download the PRONET AX app registering on MY AXIOM at the website at <https://www.axiomproaudio.com/>.

The AXIOM active loudspeaker devices can be connected in a network and controlled by the PRONET AX software, for the network connection the **USB2CAND** converter optional accessory is needed.

PRONET AX network is based on a “bus-topology” connection, where the first device is connected to the network input connector of the second device, the second device network output is connected to the network input connector of the third device, and so on. To ensure a reliable communication the first and the last device of the “bus-topology” connection must be terminated. **This can be done by pressing the “TERMINATE” switch near the network connectors in the rear panel of the first and the last device.** For the network connections simple RJ45 cat.5 or cat.6 ethernet cables can be used (please don’t confuse a ethernet network with a PRONET AX network these are completely different and must be fully separated also both use the same kind of cable).

EXAMPLE OF PRONET NETWORK WITH ED120A/150A AND SW18A

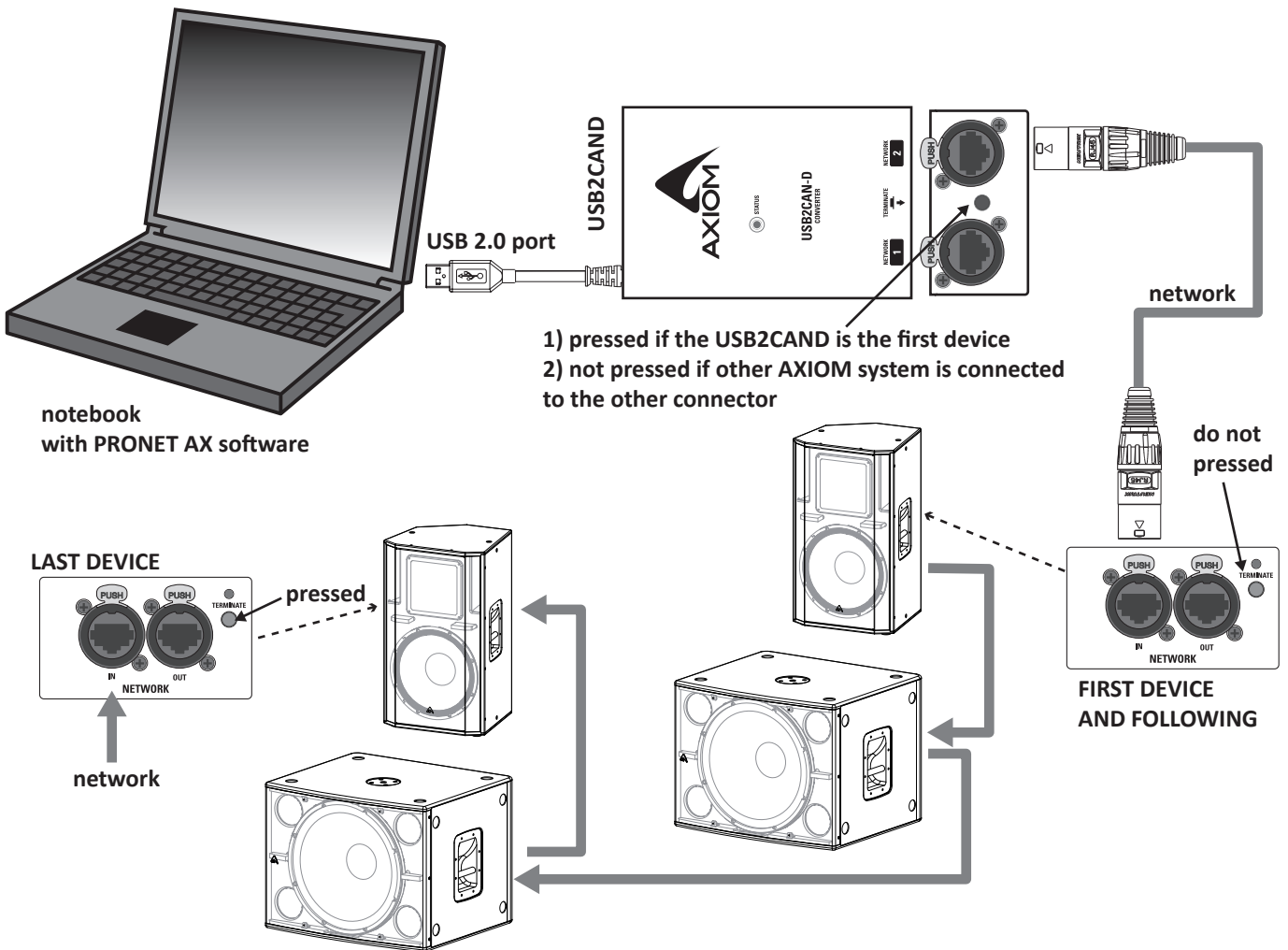



Assign the ID number

To work properly in a PRONET AX network each connected device must have a unique identifier number, called ID. By default the USB2CAN-D PC controller has ID=0 and there can be only one PC controller. Every other device connected must have its own unique ID equal or greater than 1: in the network cannot exist two devices with the same ID.

In order to correctly assign a new available ID to each device for working properly in a Pronet AX network, follow these instructions:

1. Switch off all the devices.
2. Connect them correctly to the network cables.
3. "TERMINATE" the end device in the network connection.
4. Switch on the first device keep pressed "PRESET" button on the control panel.
5. Leaving the previous device switched on, repeat the previous operation on the next device, until the latest device is turned on.

The "Assign ID" procedure for a device makes the internal network controller to perform two operations: reset the current ID; search the first free ID in the network, starting from ID=1. If no other devices are connected (and powered on), the controller assume ID=1, that is the first free ID, otherwise it searches the next one left free.

These operations ensure that every device has it's own unique ID, if you need to add a new device to the network you simply repeat the operation of step 4. Every device maintains its ID also when it is turned-off, because the identifier is stored in the internal memory and it is cleared only by another "Assign ID" step, as explained above.



With the network made always of the same devices the assigning ID procedure must be executed only the first time the system is turned on.

For more detailed instruction about PRONET AX see the PRONET AX USER'S MANUAL included with the software.



HORN ORIENTATION

ED120A features an asymmetrical horn that can be rotated in a few minutes for obtaining the best coverage according to the speaker configuration.

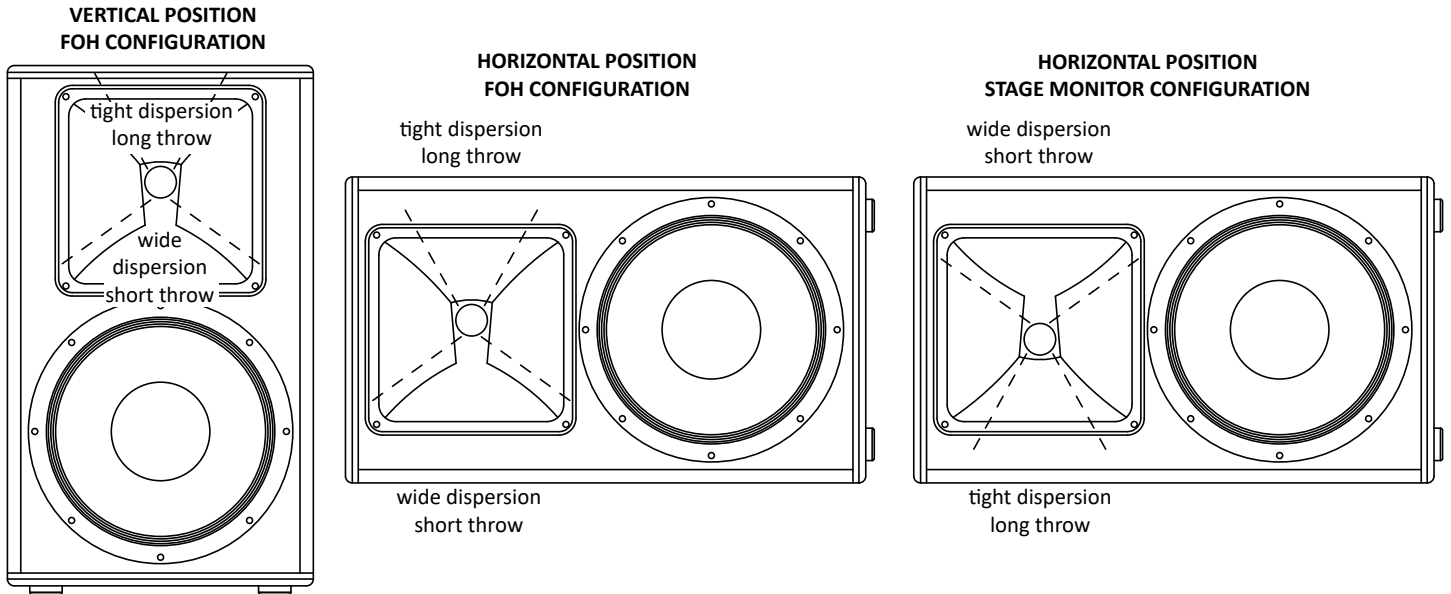

WARNING! CAREFULLY READ THE FOLLOWING INSTRUCTIONS AND CONDITION OF USE:

- For a supplementary safety assure always the loudspeaker to the wall with an alternative rope.
- This loudspeaker is designed exclusively for Professional audio applications. The product must be installed by qualified personal only.
- Proel strongly recommends that this loudspeaker cabinet be suspended taking into consideration all current National, Federal, State and Local regulations. Please contact the manufacturer for further information.
- Proel do not accept any liability for damage caused to third parties due to improper installation, lack of maintenance, tampering or improper use of this product, including disregard of acceptable and applicable safety standards.
- During assembly pay attention to the possible risk of crushing. Wear suitable protective clothing. Observe all instructions given on the rigging components and the loudspeaker cabinets. When chain hoists are in operation ensure that there is nobody directly underneath or in the vicinity of the load. Do not under any circumstances climb on the array.



KPTED120B WALL or TRUSS MOUNTING

Using the "C" shape bracket the ED120A loudspeaker can be mounted to walls or truss combining it with two PLH300: It allows to aim the speaker in one direction (vertical or horizontal) in 15 steps (0° , $\pm 10^\circ$, $\pm 15^\circ$, $\pm 25^\circ$, $\pm 30^\circ$, $\pm 40^\circ$, $\pm 55^\circ$, $\pm 70^\circ$). For installing the speaker using the "C" bracket follow these instructions:

- 1) Install the "C" bracket to the the wall or to the truss.
- 2) Mount the two steering plates on the top and bottom of the loudspeaker using the bolts (a).
- 3) Carefully put the loudspeaker into the "C" bracket then screw in the screws (b) to fix it to the "C" bracket.
- 4) Aim the loudspeaker and tighten the screw-knobs (c) in the desired holes.
- 5) Tight the screws (b).

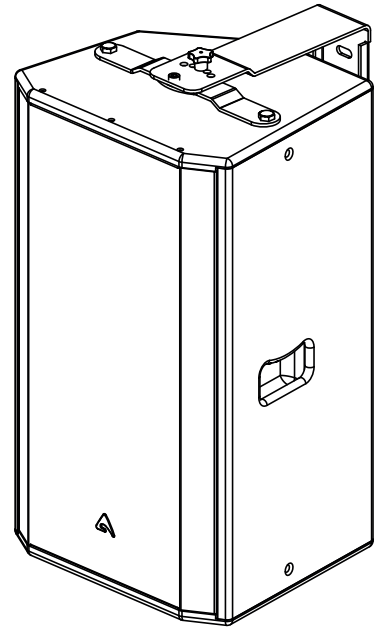
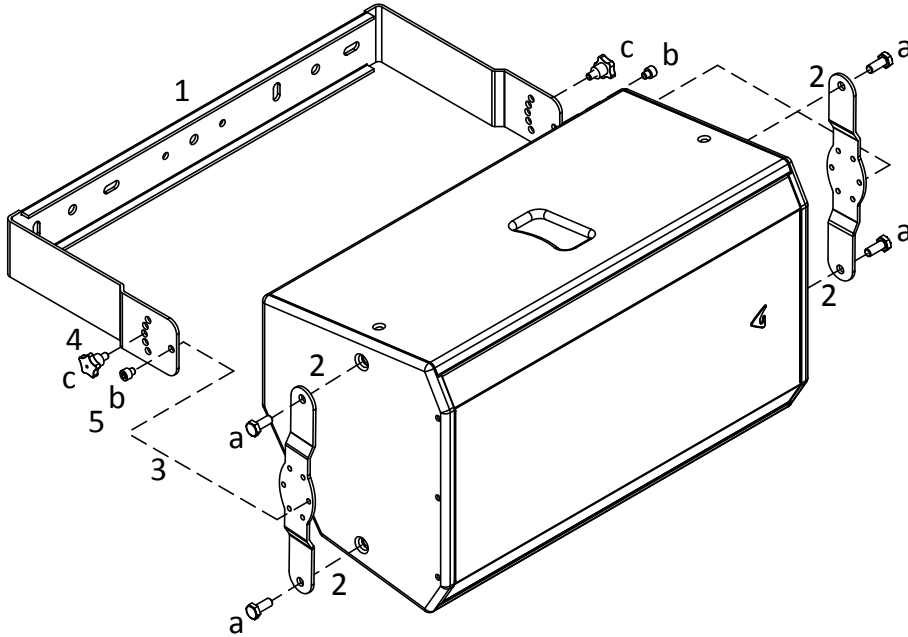



PROEL S.p.A. (World Headquarters) - Via alla Ruenia 37/43 - 64027 Sant'Omero (Te) - ITALY
Tel: +39 0861 81241 Fax: +39 0861 887862 www.axiomproaudio.com

