

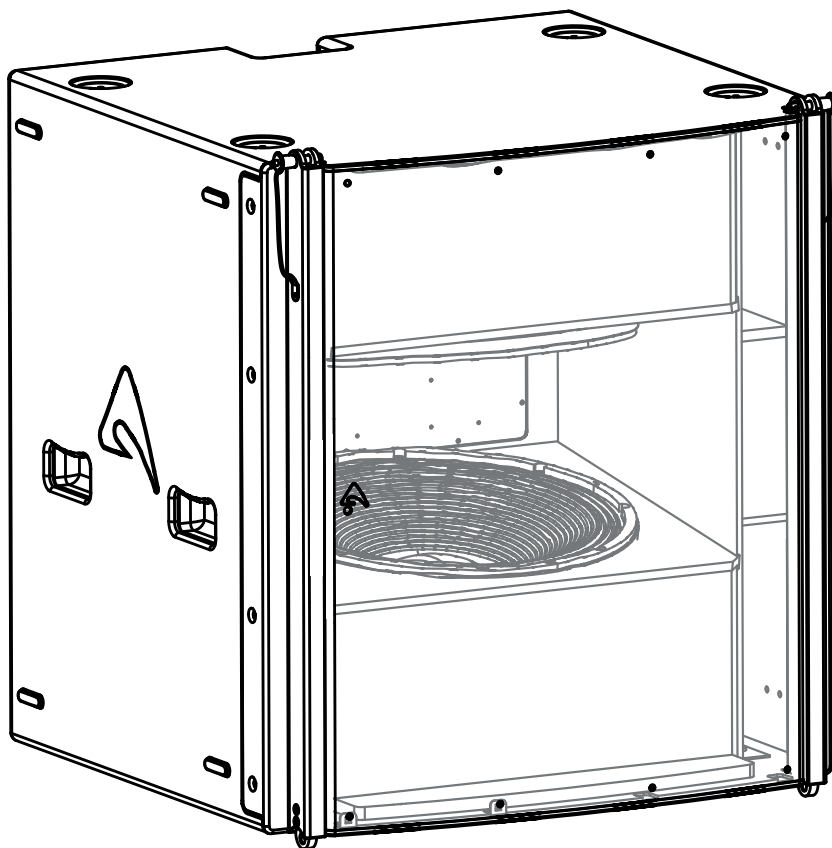

SW36XFAV2

active subwoofer



USER MANUAL

revision 2023-09-15





IMPORTANT SAFETY INSTRUCTIONS

Watch for these symbols:



The lightning flash with arrowhead symbol within an equilateral triangle is intended to alert the user to the presence of uninsulated “dangerous voltage” within the product’s enclosure, that may be of sufficient magnitude to constitute a risk of electric shock to persons.



The exclamation point within an equilateral triangle is intended to alert the user to the presence of important operating and maintenance (servicing) instructions in the literature accompanying the appliance.

1. Read these instructions.
2. Keep these instructions.
3. Heed all warnings.
4. Follow all instructions.
5. Do not use this apparatus near water.
6. Clean only with dry cloth.
7. Do not block any ventilation openings. Install in accordance with the manufacturer’s instructions.
8. Do not install near any heat sources such as radiators, heat registers, stoves, or other apparatus (including amplifiers) that produce heat.
9. Do not defeat the safety purpose of the polarized or grounding-type plug. A polarized plug has two blades with one wider than the other. A grounding-type plug has two blades and a third grounding prong. The wide blade or the third prong are provided for your safety. If the provided plug does not fit into your outlet, consult an electrician for replacement of the obsolete outlet.
10. Protect the power cord from being walked on or pinched, particularly at plugs, convenience receptacles, and the point where they exit from the apparatus.
11. Only use attachments/accessories specified by the manufacturer.
12. Use only with the cart, stand, tripod, bracket, or table specified by the manufacturer, or sold with the apparatus. When a cart is used, use caution when moving the cart/apparatus combination to avoid injury from tip-over.
13. Unplug this apparatus during lightning storms or when unused for long periods of time.
14. Refer all servicing to qualified service personnel. Servicing is required when the apparatus has been damaged in any way, such as power supply cord or plug is damaged, liquid has been spilled or objects have fallen into the apparatus, the apparatus has been exposed to rain or moisture, does not operate normally, or has been dropped.
15. Warning: to reduce the risk of fire or electric shock, do not expose this apparatus to rain or moisture.
16. Do not expose this equipment to dripping or splashing and ensure that no objects filled with liquids, such as vases, are placed on the equipment.
17. To completely disconnect this apparatus from the ac mains, disconnect the power supply cord plug from the ac receptacle.
18. The mains plug of the power supply cord shall remain readily operable.
19. This apparatus contains potentially lethal voltages. To prevent electric shock or hazard, do not remove the chassis, input module or ac input covers. No user serviceable parts inside. Refer servicing to qualified service personnel.
20. The loudspeakers covered by this manual are not intended for high moisture outdoor environments. Moisture can damage the speaker cone and surround and cause corrosion of electrical contacts and metal parts. Avoid exposing the speakers to direct moisture.
21. Keep loudspeakers out of extended or intense direct sunlight. The driver suspension will prematurely dry out and finished surfaces may be degraded by long-term exposure to intense ultra-violet (UV) light.
22. The loudspeakers can generate considerable energy. When placed on a slippery surface such as polished wood or linoleum, the speaker may move due to its acoustical energy output.
23. Precautions should be taken to assure that the speaker does not fall off a stage or table on which it is placed.
24. The loudspeakers are easily capable of generating sound pressure levels (SPL) sufficient to cause permanent hearing damage to performers, production crew and audience members. Caution should be taken to avoid prolonged exposure to SPL in excess of 90 dB.

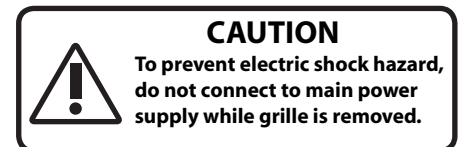

This marking shown on the product or its literature, indicates that it should not be disposed with other household wastes at the end of its working life. To prevent possible harm to the environment or human health from uncontrolled waste disposal, please separate this from other types of wastes and recycle it responsibly to promote the sustainable reuse of material resources. Household users should contact either the retailer where they purchased this product, or their local government office, for details of where and how they can take this item for environmentally safe recycling. Business users should contact their supplier and check the terms and conditions of the purchase contract. This product should not be mixed with other commercial wastes for disposal.



FEDERAL COMMUNICATIONS COMMISSION (FCC) STATEMENT

This equipment has been tested and found to comply with the limits for a Class A digital device, pursuant to part 15 of the FCC Rules. These limits are designed to provide reasonable protection against harmful interference when the equipment is operated in a commercial environment. This equipment generates, uses, and can radiate radio frequency energy and, if not installed and used in accordance with the instruction manual, may cause harmful interference to radio communications.

Operation of this equipment in a residential area is likely to cause harmful interference in which case the user will be required to correct the interference at their own expense.

This device complies with Part 15 of the FCC rules. Operation is subject to the following two conditions:

- (1) this device may not cause harmful interference, and
- (2) this device must accept any interference received, including interference that may cause undesired operation.

DECLARATION OF CONFORMITY

CE The product is in compliance with:
EMC Directive 2014/30/EU, LVD Directive 2014/35/EU, RoHS Directive 2011/65/EU and 2015/863/EU, WEEE Directive 2012/19/EU.

EN 55032 (CISPR 32) STATEMENT

Warning: This equipment is compliant with Class A of CISPR 32. In a residential environment this equipment may cause radio interference. Under the EM disturbance, the ratio of signal-noise will be changed above 10 dB.

UK CA The product is in compliance with:
S.I. 2016/1091 Electromagnetic Compatibility Regulations 2016, S.I. 2016/1101 Electrical Equipment (Safety) Regulations 2016, S.I. 2012/3032 The Restriction of the Use of Certain Hazardous Substances in Electrical and Electronic Equipment Regulations 2012.

CISPR 32 STATEMENT

Warning: This equipment is compliant with Class A of CISPR 32. In a residential environment this equipment may cause radio interference. Under the EM disturbance, the ratio of signal-noise will be changed above 10 dB.

LIMITED WARRANTY

Proel warrants all materials, workmanship and proper operation of this product for a period of two years from the original date of purchase. If any defects are found in the materials or workmanship or if the product fails to function properly during the applicable warranty period, the owner should inform about these defects the dealer or the distributor, providing receipt or invoice of date of purchase and defect detailed description. This warranty does not extend to damage resulting from improper installation, misuse, neglect or abuse. Proel S.p.A. will verify damage on returned units, and when the unit has been properly used and warranty is still valid, then the unit will be replaced or repaired. Proel S.p.A. is not responsible for any "direct damage" or "indirect damage" caused by product defectiveness.

- This unit package has been submitted to ISTA 1A integrity tests. We suggest you control the unit conditions immediately after unpacking it.
- If any damage is found, immediately advise the dealer. Keep all unit packaging parts to allow inspection.
- Proel is not responsible for any damage that occurs during shipment.
- Products are sold "delivered ex warehouse" and shipment is at charge and risk of the buyer.
- Possible damages to unit should be immediately notified to forwarder. Each complaint for package tampered with should be done within eight days from product receipt.

CONDITIONS OF USE

Proel do not accept any liability for damage caused to third parties due to improper installation, use of non-original spare parts, lack of maintenance, tampering or improper use of this product, including disregard of acceptable and applicable safety standards. Proel strongly recommends that this loudspeaker cabinet be suspended taking into consideration all current National, Federal, State and Local regulations. The product must be installed by qualified personal. Please contact the manufacturer for further information.



INDEX

INTRODUCTION	4
TECHNICAL SPECIFICATION	4
MECHANICAL DRAWING	5
OPTIONAL ACCESSORIES	5
SPARE PARTS	6
I/O AND CONTROL OPERATIONS	6
MAINS~ IN.	6
MAINS~ OUT.	6
ON	6
PROT	6
SIGN LIMIT	6
INPUT	6

LINK	6
GND LIFT	6
NETWORK IN/OUT	6
TERMINATE	6
PRESET BUTTON	7
PRONET AX	8
PREDICTION SOFTWARE: EASE FOCUS 3	9
AIMING and SUSPENDING	
INSTRUCTIONS (FLOWN SET UP)	10
CARDIOID SET UP	14

INTRODUCTION

The SW36XFAV2 subwoofer is designed to deliver high quality low frequency reproduction where very high output is a key requirement, together with well defined deep bass response and fast transient response. Its compact size and light weight make it suitable for several different uses, ranging from touring applications to fixed installations and high-level dance clubs.

The SW36XFAV2 is a very high quality powered subwoofer system featuring some of the most advanced technologies for low frequency reproduction. Its unique and innovative design is based on a configuration that can be defined as Manifolded Band Pass. It uses manifolding of the front side of the cones to maximize the mutual coupling between the two drivers. This innovative configuration does not use any large resonant cavity to load the speaker, but very compact cavities in order to obtain advantages in terms of definition, both at the lowest end and the upper bass.

The SW36XFAV2 subwoofer system is equipped with two high power 18" (460mm) transducers capable of very long excursion (up to 30mm peak-to-peak), and featuring a large displacement suspension system. These transducers use Tetracoil technology, where two different, axially separated magnetic gaps and two inside-outside 100mm (4") diameter voice coils are wound on the same former and suspended evenly in the two magnetic gaps. This creates an equivalent voice coil diameter greater than 6", resulting in a larger heat dissipation area for and increased power handling. Additional key advantages of the Tetracoil technology are also minimized distortion and a very symmetric and flat inductance curve. Cones are made of very high-stiffness fiberglass reinforced paper, featuring also invisible water repellent treatment. The SW36XFAV2 is processed by 40bit floating point CORE2 DSP and is powered by a high efficiency CLASS D amplifier module with a newly designed power supply equipped with PFC, which reduces the power consumption while enhancing reliability and consistency in all operating conditions. The innovative technology used for these amplifiers offers performance at the top of the range, such as superior sound definition at any audio frequency, very high dynamics for low level signals, and very low distortion even at maximum power.

TECHNICAL SPECIFICATION

SYSTEM		Amplifier Type	Class D amplifier with SMPS & PFC
System's Acoustic Principle	Manifolded Band Pass	Output Power	2000 W + 2000 W
Frequency response (±3 dB)	36 Hz – 100 Hz (Processed)	Mains Voltage Range (Vac)	100 - 240 V~ ±10% 50/60 Hz
Maximum Peak SPL @ 1m	143 dB	Consumption*	600 W (nominal) 2000 W (max)
TRANSDUCERS		IN / OUT Connectors	Neutrik XLR-M / XLR-F
Type	Two 18" (460 mm), 4" (100 mm) VC 8Ω	IN / OUT Network Connectors	ETHERCON® (NE8FAV)
Cone	Water repellent, epoxy coated plates	Mains Connector	PowerCon® (NAC3MPXXA)
	100mm (4in) Tetracoil dual voice coil, equivalent to a single coil diameter larger than 152mm (>6in)	Mains Link Connector	PowerCon® (NAC3MPXXB)
Voice Coil Type		Cooling	Variable speed DC fan
Suspension	Ultra linear suspension behavior	ENCLOSURE & CONSTRUCTION	
ELECTRICAL		Width	746 mm (29.4")
Input Impedance	20 kΩ balanced	Height	795 mm (31.3")
Input Sensitivity	+4 dBu / 1.25 V	Depth	710 mm (27.9")
	CORE2 processing, 40bit floating point SHARC DSP, 24 bit AD/DA converters	Depth Including Wheels	838 mm (32.9")
Signal Processing		Enclosure material	15 mm, reinforced Phenolic Birch
Direct access Controls	4 Presets: Standard, InfraSub, Cardioid, User. Network Termination, GND Link	Paint	High resistance, water based paint
Remote Controls	PRONET AX control software	Wheels	4 heavy-load 100 mm ø (optional)
Network protocol	CANBUS	Transport	6 handles
		Side Suspension	High Strength Steel with ¼ Fast Pin
		Back Suspension	High Strength Steel with ¼ Fast Pin
		Net Weight	91.2 Kg (201.1 lbs.) without wheels

* Nominal consumption is measured with pink noise with a crest factor of 12 dB, this can be considered a standard music program.



MECHANICAL DRAWING

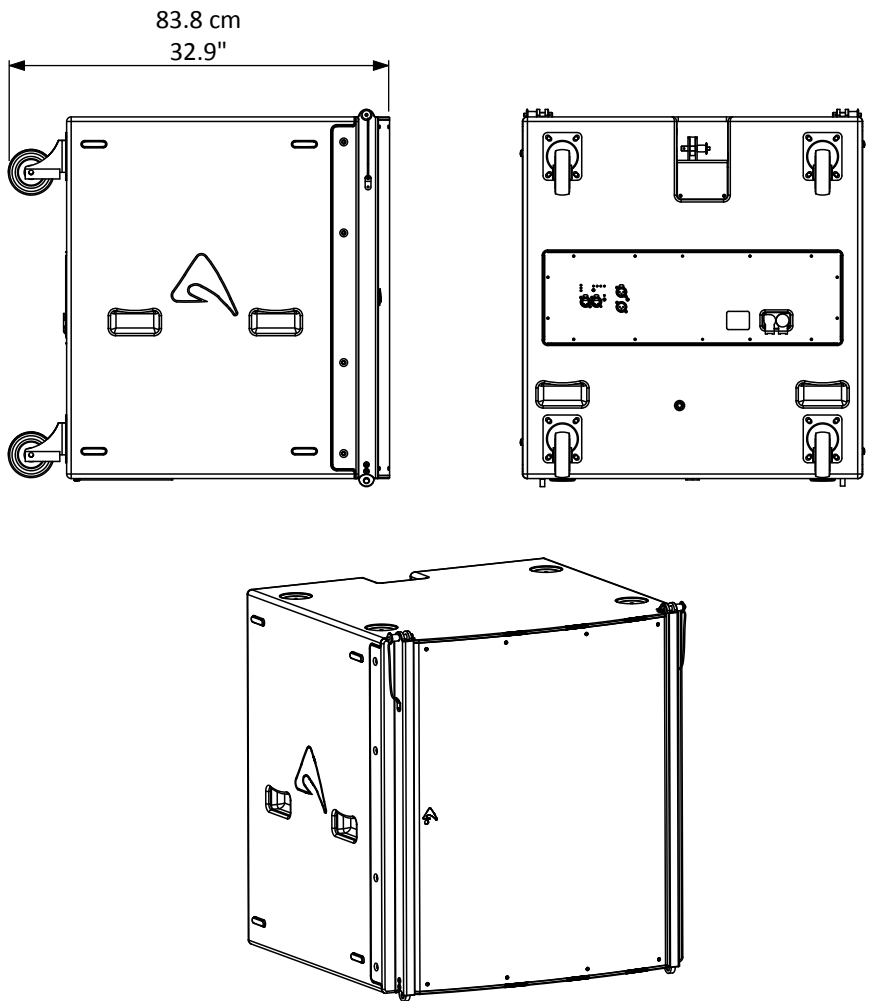
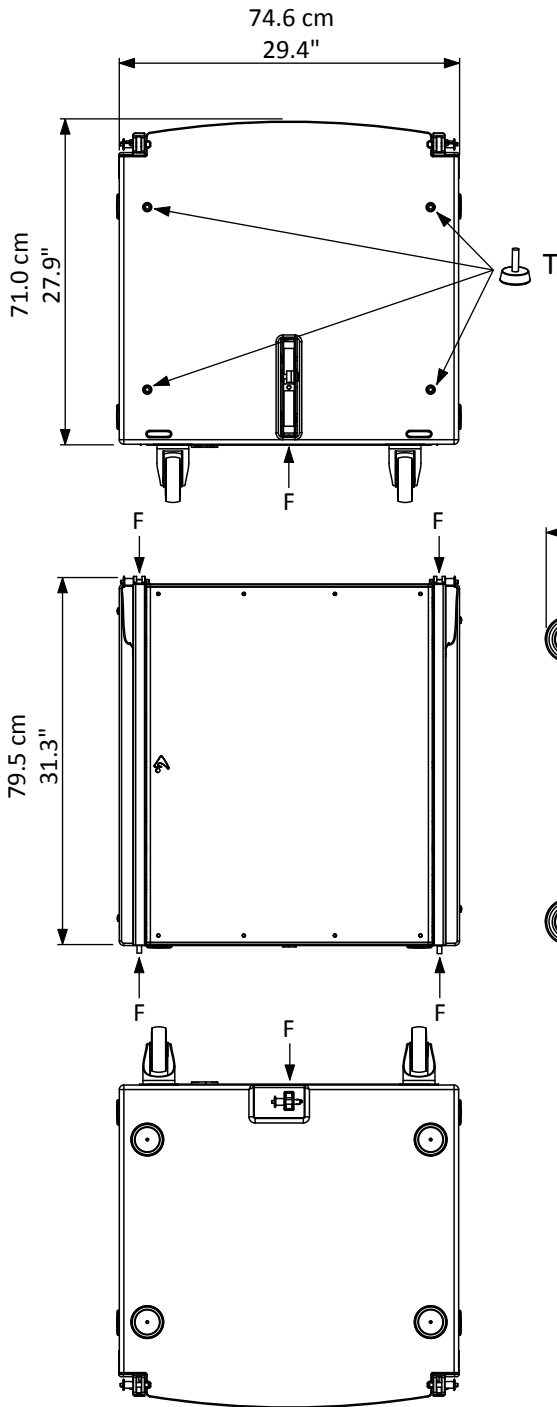

OPTIONAL ACCESSORIES

- NAC3FX-W-TOP-L** Neutrik Powercon® TRUE1 (for power in)*
- NAC3MX-W-TOP-L** Neutrik Powercon® TRUE1 (for power out)*
- HTLACA** Tool for tightening powerCON TRUE1*
- HTLACB** Tool for tightening powerCON TRUE1*
- NE8MC-B-1** Neutrik Ethercon PLUG
- USB2CANDV2** Dual Port PRONET AX network converter

- AXFEETKIT** Kit made of 6pcs BOARDACF01 foot
- KPTSW36XF** Fly bar for Axiom SW36XF and AX2010 Loudspeakers
- AC103GS** 100 mm Swivel castor without brake
- AVCAT5PROxx** Cat5e on cable drum, 30/50/75 m Length

see <http://www.axiomproaudio.com/> for detailed description and other available accessories.

*Note: See assembly instruction downloadable from NEUTRIK WEB site at: <http://www.neutrik.com/>





SPARE PARTS

91AMDSW36V2	Amplifier module assembly	91DALITEMOD4HV	Powersoft LITEMOD4HV amplifier module
NAC3PX-TOP	Neutrik Powercon® TRUE1 inlet-outlet	98AXM218TLW4	18" woofer - 4" Tetracoil® dual voice coil - 4 ohm
SCNAC-04	Neutrik Rubber Sealing for NAC3PX	95AXM014	Locking Pin for AX2010
91DSPKT11	Input, Control and CORE2 DSP PCBA		

I/O AND CONTROL OPERATIONS

MAINS~ IN

Powercon® NAC3PX power inlet connector. To switch the amplifier on, insert the Powercon® connector and turn it clockwise into the ON position. To switch the amplifier off, pull back the switch on the connector and turn it counter-clockwise into the POWER OFF position.

MAINS~ OUT

Powercon® NAC3PX power outlet connector. This is connected in parallel with the MAINS~ IN.



WARNINGS:

- Connect no more than one subwoofer unit to the MAINS~ OUT connector.
- If you use the MAINS~ OUT turn on each subwoofer unit one a time.
- In the case of product failure or fuse replacement, disconnect the unit completely from the mains power.
- Use a suitable power cable and mains plug to build the power cable, it must only be connected to a socket corresponding to the specifications indicated on the amplifier unit.
- See assembly instruction downloadable from NEUTRIK WEB site at: <http://www.neutrik.com/>

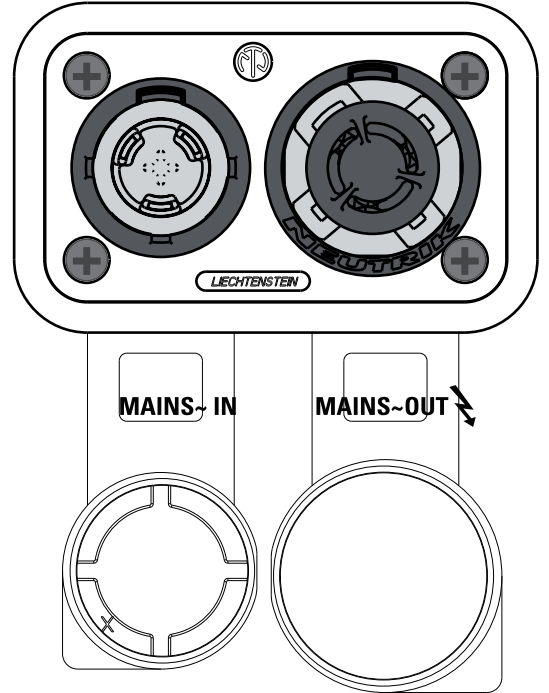

ON

This LED indicates power on status.

PROT

This red LED lights when the amplifier module is in protect mode for an internal fault and, consequently, the amplifier is muted.

SIGN LIMIT

This LED lights in green to indicate the presence of the signal and lights in red when an internal limiter reduces the input level.

INPUT

Audio signal input with locking XLR connector. It has a fully electronically balanced circuitry including AD conversion for the best S/N ratio and input headroom.

LINK

A direct connection from the input connector to link other speakers with same audio signal.

GND LIFT

This switch lift the ground of the balanced audio inputs from the earth-ground of the amplifier module.

NETWORK IN/OUT

These are a standard RJ45 CAT5 connectors (with optional NEUTRIK NE8MC RJ45 cable connector carrier), used for PRONET network transmission of remote control data over long distance or multiple unit applications.

TERMINATE

In a PRONET network the last loudspeaker device must be terminated (with an inner load resistance) especially in a long run cabling: press this switch if you want to terminate the unit.

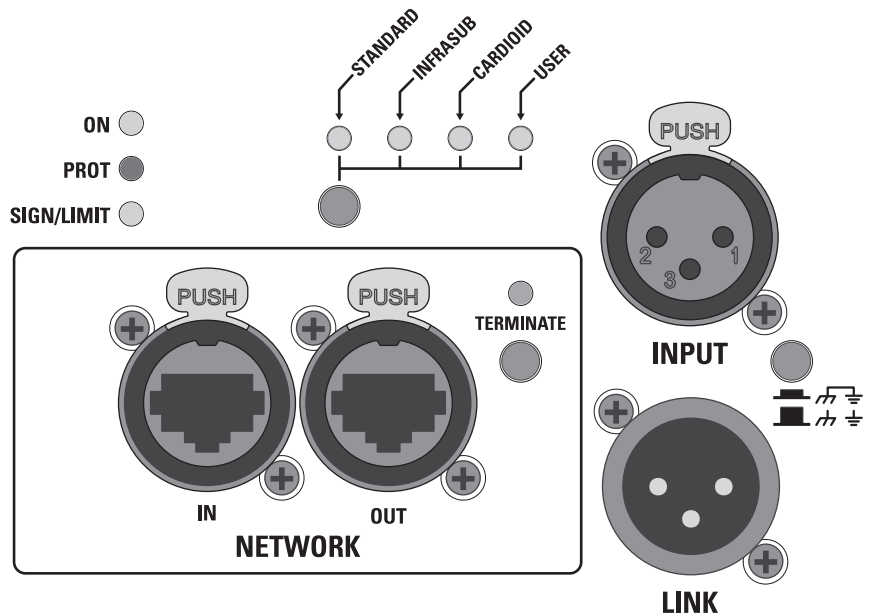



PRESET BUTTON

This button has two function:

1) Pressing it while powering on the unit:

ID ASSIGN The internal DSP assigns a new ID to the unit for the PRONET AX remote control operation. Each loudspeaker must have a unique ID to be visible in the PRONET AX network. When you assign a new ID, all the other loudspeakers with the ID already assigned must be ON and connected to the network.

2) Pressing it with the unit ON you can select the DSP PRESET. The selected PRESET is indicated by the corresponding LED:

STANDARD This PRESET is suitable for any application where low frequency reinforcement is required. The response starts at 45Hz and the cutoff is at 100Hz with LR 24dB/oct., use this preset for almost any application at ground stack and it must be used with the SW36XFAV2 set as flown (see FLOWN SET UP).

INFRA This PRESET can be used when a deeper bass response is required (Note that when this preset is used the sound pressure level of the system is slightly reduced). The response starts at 36Hz and the cutoff is at 60Hz with LR 24dB/oct.

NOTE: INFRA and STANDARD PRESET must NOT be used together in close units.

CARDIOID This special PRESET, combined with the STANDARD PRESET, gives the advantage to reduce the low frequencies at the back of an array of three subs, in order to obtain a more comfortable level for the performers on the stage without losing level for the the audience in front of the array. The cardioid configuration is also useful in situation where you want to reduce the bass frequency feedback due to many microphones on stage, for example for acoustic and jazz ensemble, classic orchestra, musicals. Further in this manual you can find some example how to set up a cardioid array.

USER This PRESET corresponds to USER MEMORY no. 1 of the DSP and, as a factory setting, it's the same to STANDARD. If you want to modify it, you have to connect the unit to a PC, edit the parameters with PRONET AX software and save the PRESET into USER MEMORY no. 1.

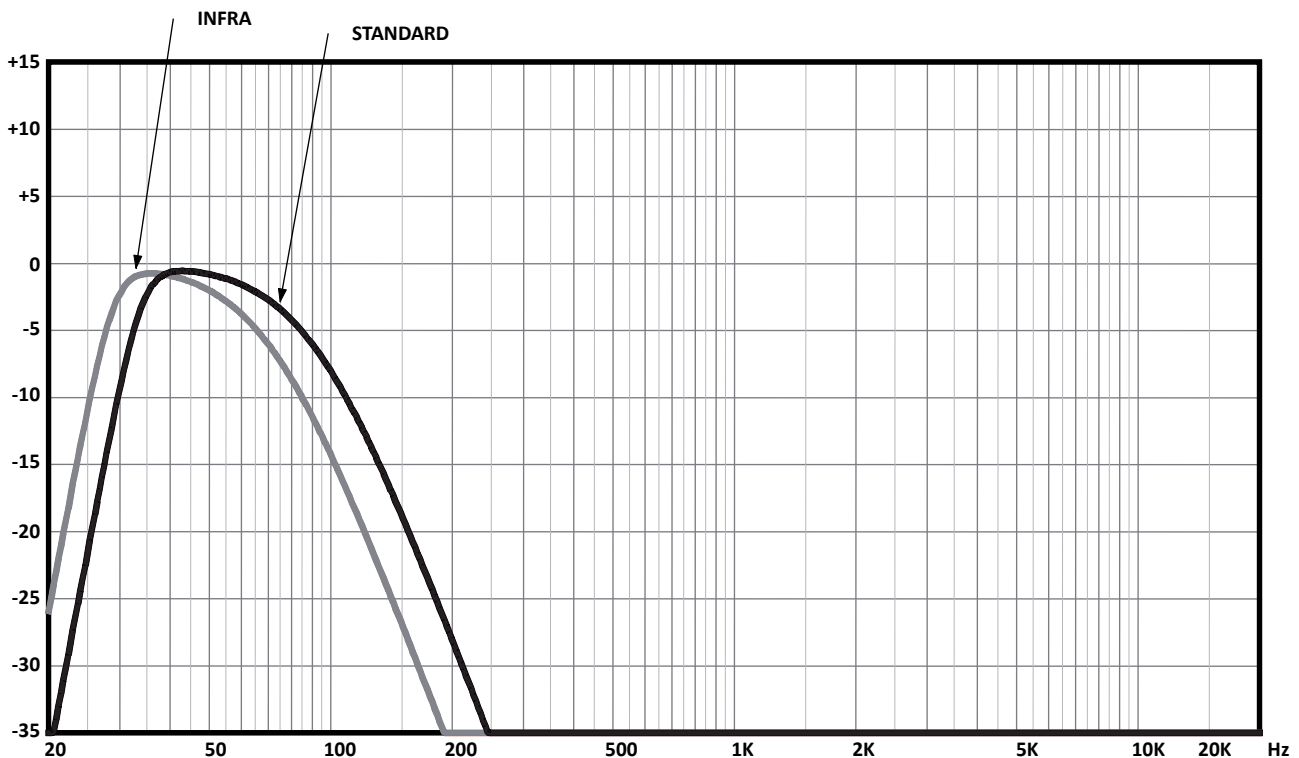

WARNING! CAREFULLY READ THE FOLLOWING INSTRUCTIONS AND CONDITION OF USE:

- This loudspeaker is designed exclusively for Professional audio applications. The product must be installed by qualified personal only.
- Proel strongly recommends that this loudspeaker cabinet be suspended taking into consideration all current National, Federal, State and Local regulations. Please contact the manufacturer for further information.
- Proel do not accept any liability for damage caused to third parties due to improper installation, lack of maintenance, tampering or improper use of this product, including disregard of acceptable and applicable safety standards.
- During assembly pay attention to the possible risk of crushing. Wear suitable protective clothing. Observe all instructions given on the rigging components and the loudspeaker cabinets. When chain hoists are in operation ensure that there is nobody directly underneath or in the vicinity of the load. Do not under any circumstances climb on the array.



PRONET AX

PRONET AX software has been developed in collaboration with sound engineers and sound designers, in order to offer an “easy-to-use” tool to setup and manage your audio system. With PRONET AX you can visualize signal levels, monitor internal status and edit all the parameters of each connected device.

Download the PRONET AX app registering on MY AXIOM at the website at <https://www.axiomproaudio.com/>.

The AXIOM active loudspeaker devices can be connected in a network and controlled by the PRONET AX software, for the network connection the **USB2CAND** (with 2-port) converter optional accessory is needed. PRONET AX network is based on a “bus-topology” connection, where the first device is connected to the network input connector of the second device, the second device network output is connected to the network input connector of the third device, and so on. To ensure a reliable communication the first and the last device of the “bus-topology” connection must be terminated. **This can be done by pressing the “TERMINATE” switch near the network connectors in the rear panel of the first and the last device.** For the network connections simple RJ45 cat.5 or cat.6 ethernet cables can be used (please don’t confuse a ethernet network with a PRONET AX network these are completely different and must be fully separated also both use the same kind of cable).

EXAMPLE OF PRONET AX NETWORK WITH AX2010A AND SW36XFA

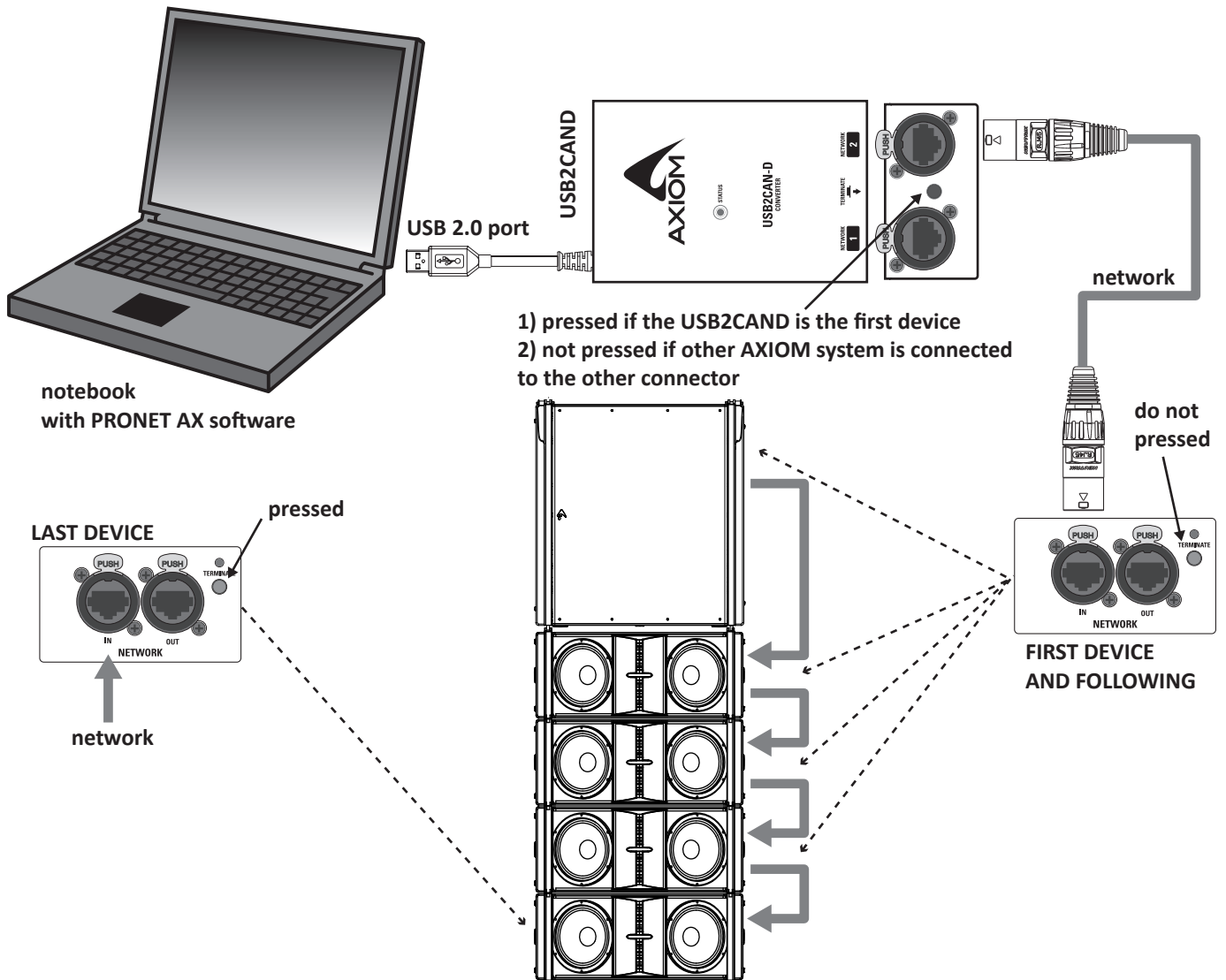



Assign the ID number

To work properly in a PRONET AX network each connected device must have a unique identifier number, called ID. By default the USB2CAN-D PC controller has ID=0 and there can be only one PC controller. Every other device connected must have its own unique ID equal or greater than 1: in the network cannot exist two devices with the same ID.

In order to correctly assign a new available ID to each device for working properly in a Pronet AX network, follow these instructions:

1. Switch off all the devices.
2. Connect them correctly to the network cables.
3. "TERMINATE" the end device in the network connection.
4. Switch on the first device keep pressed "PRESET" button on the control panel.
5. Leaving the previous device switched on, repeat the previous operation on the next device, until the latest device is turned on.

The "Assign ID" procedure for a device makes the internal network controller to perform two operations: reset the current ID; search the first free ID in the network, starting from ID=1. If no other devices are connected (and powered on), the controller assume ID=1, that is the first free ID, otherwise it searches the next one left free.

These operations ensure that every device has it's own unique ID, if you need to add a new device to the network you simply repeat the operation of step 4. Every device maintains its ID also when it is turned-off, because the identifier is stored in the internal memory and it is cleared only by another "Assign ID" step, as explained above.



With the network made always of the same devices the assigning ID procedure must be executed only the first time the system is turned on.

For more detailed instruction about PRONET AX see the PRONET AX USER'S MANUAL included with the software.

PREDICTION SOFTWARE: EASE FOCUS 3

To aim correctly a complete system we suggests to use always the Aiming Software - EASE Focus 3:

The EASE Focus 3 Aiming Software is a 3D Acoustic Modelling Software that serves for the configuration and modelling of Line Arrays and conventional speakers close to reality. It only considers the direct field, created by the complex addition of the sound contributions of the individual loudspeakers or array components.

The design of EASE Focus is targeted at the end user. It allows the easy and quick prediction of the array performance in a given venue. The scientific base of EASE Focus stems from EASE, the professional electro- and room acoustic simulation software developed by AFMG Technologies GmbH. It is based on the EASE GLL loudspeaker data file required for its use. The GLL file contains the data that defines the Line Array with regard to its possible configurations as well as to its geometrical and acoustical properties.



Download the EASE Focus 3 app from the AXIOM website at <https://www.axiomproaudio.com/> clicking on downloads section of the product.

Use the menu option **Edit / Import System Definition File** to import the GLL file, the detailed instructions to use the program are located in the menu option **Help / User's Guide**.

Note: Some windows system can require the .NET Framework 4 that can be download from website at <https://focus.afmg.eu/>.

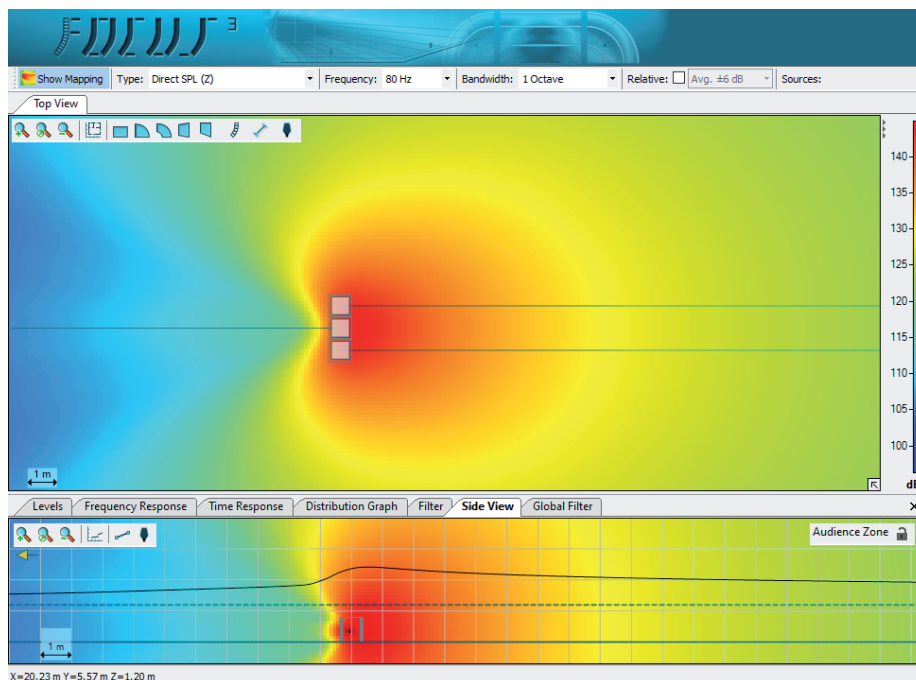

NOTE: in this figure is shown the result of an horizontal cardioid ground stack for the 80Hz octave.





AIMING and SUSPENDING INSTRUCTIONS (FLOWN SET UP)

Suspending the sub-woofers has different advantages and some inconvenient. One inconvenient is that it's not possible to use the cardioid configuration, while another one is that as the sub-woofers don't couple with the ground and indoor usage can have different behaviours depending on ceiling and walls. The advantages are that the space underneath the stage can be free from subs, the coupling between sub and sat is better and, using a column of 4-6 sub boxes, the basses can be steered more deeply into the audience with a more uniform distribution of the low frequencies.

The SW36XFAV2 subwoofers can be suspended alone or at the top of a vertical array of AX2010A loudspeakers using the KPTSW36 fly bar. The boxes are linked together in a column using a series of couplers integrated in the frame of each enclosure. Each system can be set properly both acoustically and mechanically, using the aiming software.

Coupling the system in the front does not require any adjustment: using two locking pins, each loudspeaker box is fixed to the previous. The slotted bar in the back is inserted in a U-shaped frame that features a series of numbered holes. Sliding the slotted bar in the U-shaped frame of the next loudspeaker and inserting a locking pin in one of the numbered holes, it is possible to adjust the relative splay angle between two adjacent loudspeakers in the array column.

KPTSW36 fly bar maximum capacity is 780 Kg (1719 lbs) with the 0° angle. It can support, with a safety factor of 10:1, up to:

- 16 AX2010A (flybar from 0 to 10°)
- 2 SW36XFAV2 + 12 AX2010A (flybar from 0 to 10°)
- 6 SW36XFAV2 + 4 AX2010A (flybar from 0 to 10°)
- 8 SW36XFAV2 (flybar at 0°)

KPTSW36 FLY BAR AND ACCESSORIES

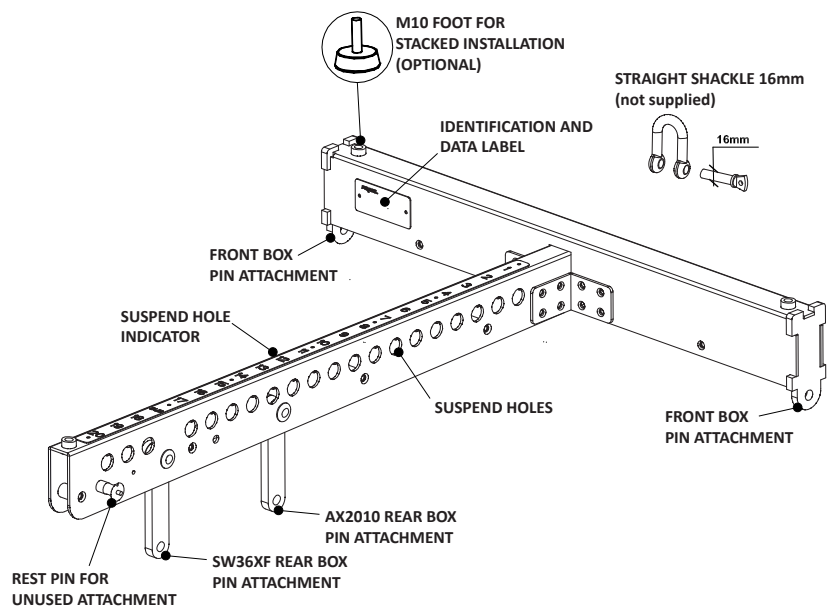

Wind loads

When planning an open-air event it is essential to obtain current weather and wind information. When loudspeaker arrays are flown in an open-air environment, possible wind effects must be taken into account. Wind load produces additional dynamic forces acting on the rigging components and the suspension, which may lead to a dangerous situation. If according to the forecast wind forces higher than 5 bft (29-38 Km/h) are possible, the following actions have to be taken:

- The actual on-site wind speed has to be monitored permanently. Be aware that wind speed typically increases with height above ground.
- Suspension and securing points of the array should be designed to support double the static load in order to withstand any additional dynamic forces.



WARNING!

Flying loudspeakers overhead at wind forces higher than 6 bft (39-49 Km/h) is not recommended.

If the wind force exceeds 7 bft (50-61 Km/h) there is a risk of mechanical damage to the components which may lead to a dangerous situation for persons in the vicinity of the flown array.

- **Stop the event and make sure that no person remains in the vicinity of the array.**
- **Lower and secure the array.**



KPTSW36 FLY BAR ASSEMBLY SEQUENCE

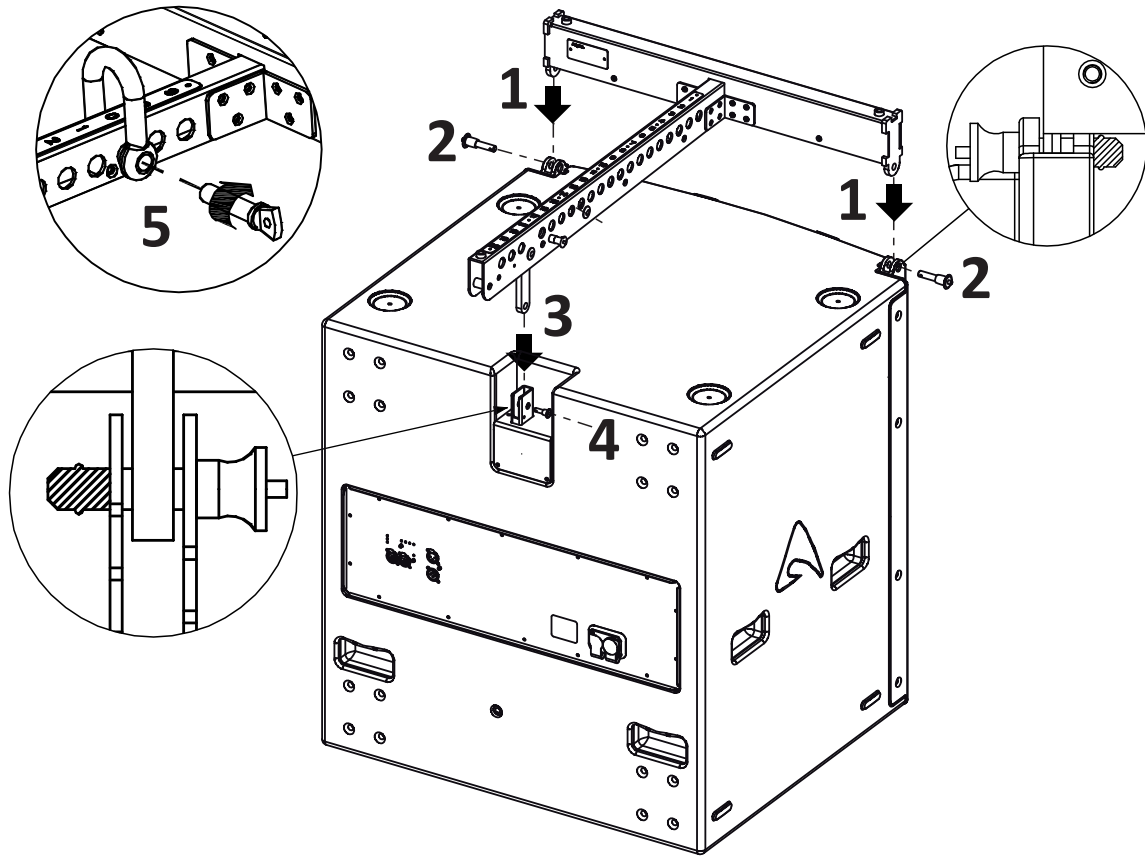

Follow the sequence in the figure for fixing the fly bar at the first box. Usually this is the first step before lifting up the system. Be careful to insert properly all the locking pins (1)(2) and (3)(4) then the shackle (5) in the right holes as specified by the aiming software.

When lifting the system always proceed gradually step by step, paying attention to secure the fly bar to the box (and the box to the other boxes) before pulling up the system: this makes easier to insert properly the locking pins. Also when the system is released down, unlock gradually the pins.

During the lifting be very careful to not let the cables enter the space between one enclosure and the other, as their compression could cut them.

Please note that the bottom Rear Link Bar of the SW36XFAV2 cabinet is retained in the guide with a magnet, force it to release it down, it is free to slide from rear to front of the box (see figure): the backward position is to link another SW36XFAV2 box, the forward position is to link a AX2010A box.

SW36XFA/P REAR LINK BAR

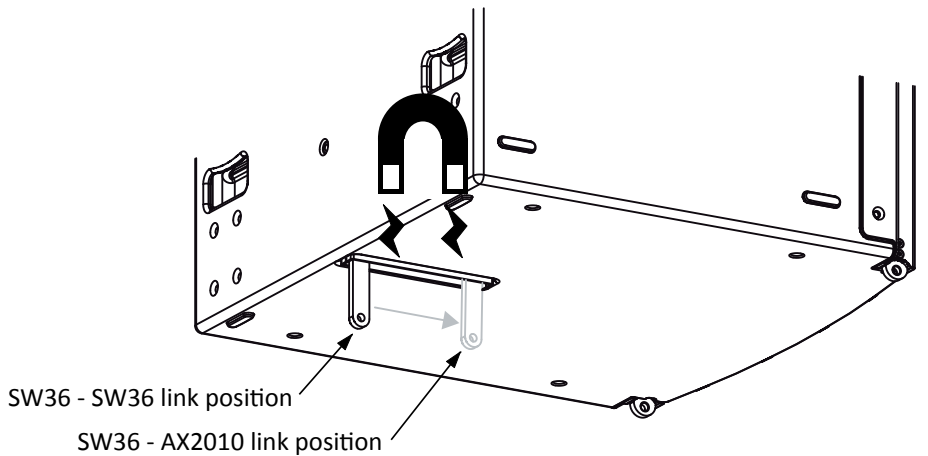

**KPTSW36 - SW36XFA - SW36XFA
ARRAY ASSEMBLING SEQUENCE**

**MAX:
KPTSW36
+
8x SW36XFA**

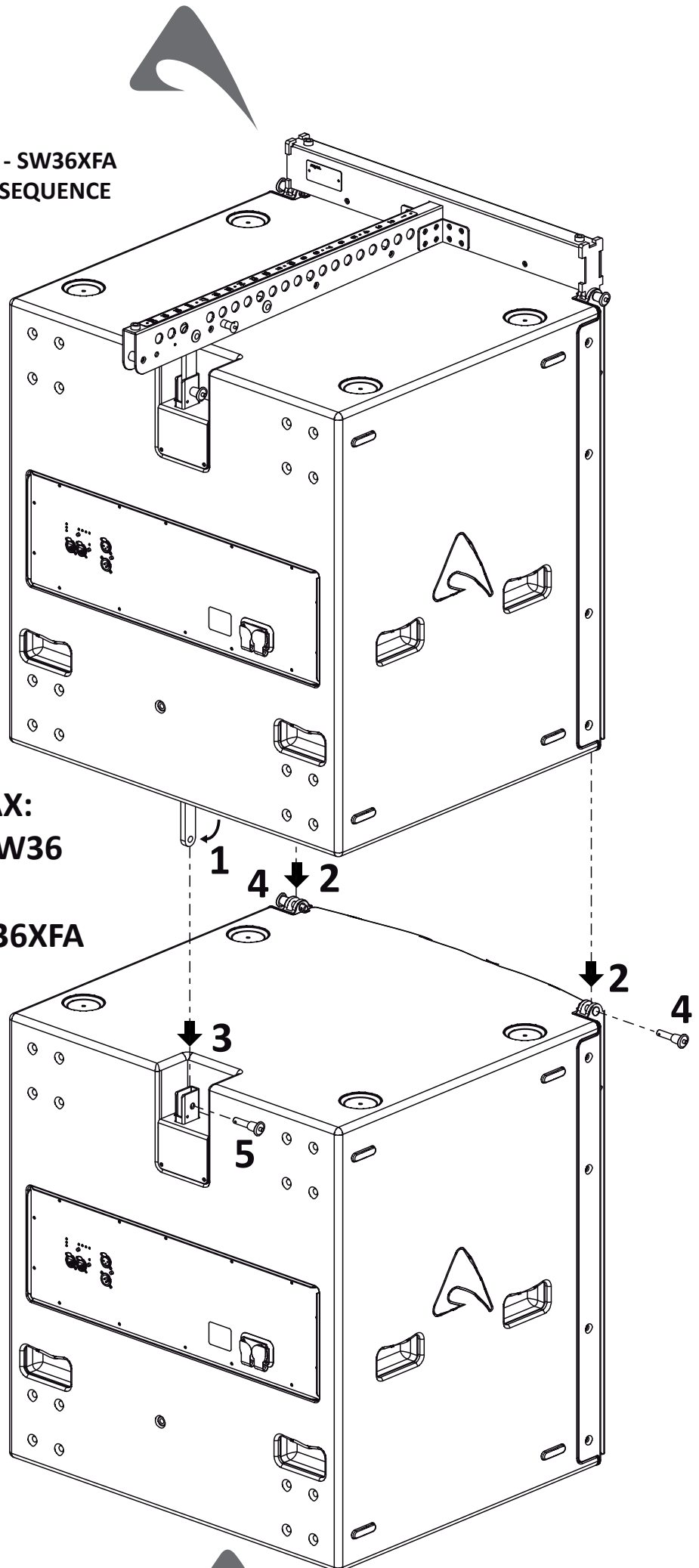



KPTSW36 - SW36XFA - AX2010A ASSEMBLING SEQUENCE

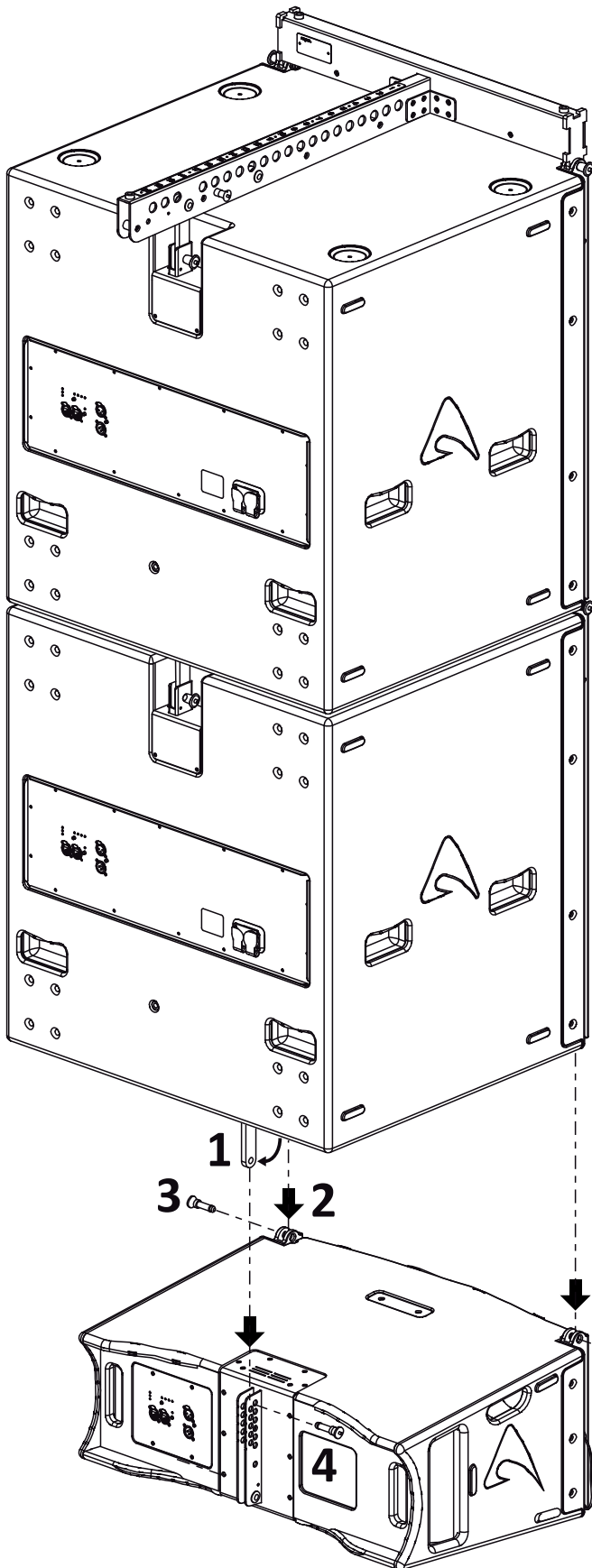

MAX:
KPTSW36
+
2x SW36XFA
+
12x AX2010A





CARDIOID SET UP

The cardioid preset must be used in a sub array of three SW36XFAV2. Two boxes must be oriented towards the audience and one must be turned in the opposite direction (typically the box in the centre of the array). The bottom and the top boxes must have the STANDARD PRESET, the box in the middle must have the CARDIOID PRESET. The audio signal sent to all boxes is the same.

The CARDIOID PRESET has the same response of the STANDARD PRESET, but to obtain the maximum cancellation on the back side of the array it has the phase inverted and a proper level and delay setting.

The figure below shows two typical displacement of the array. The first with all the boxes in a vertical position one above the other for a total height of 2400 mm and a width of 750 mm. The second with all the boxes in a vertical position next to each other for a total height of 800 mm and a width of 2240 mm.

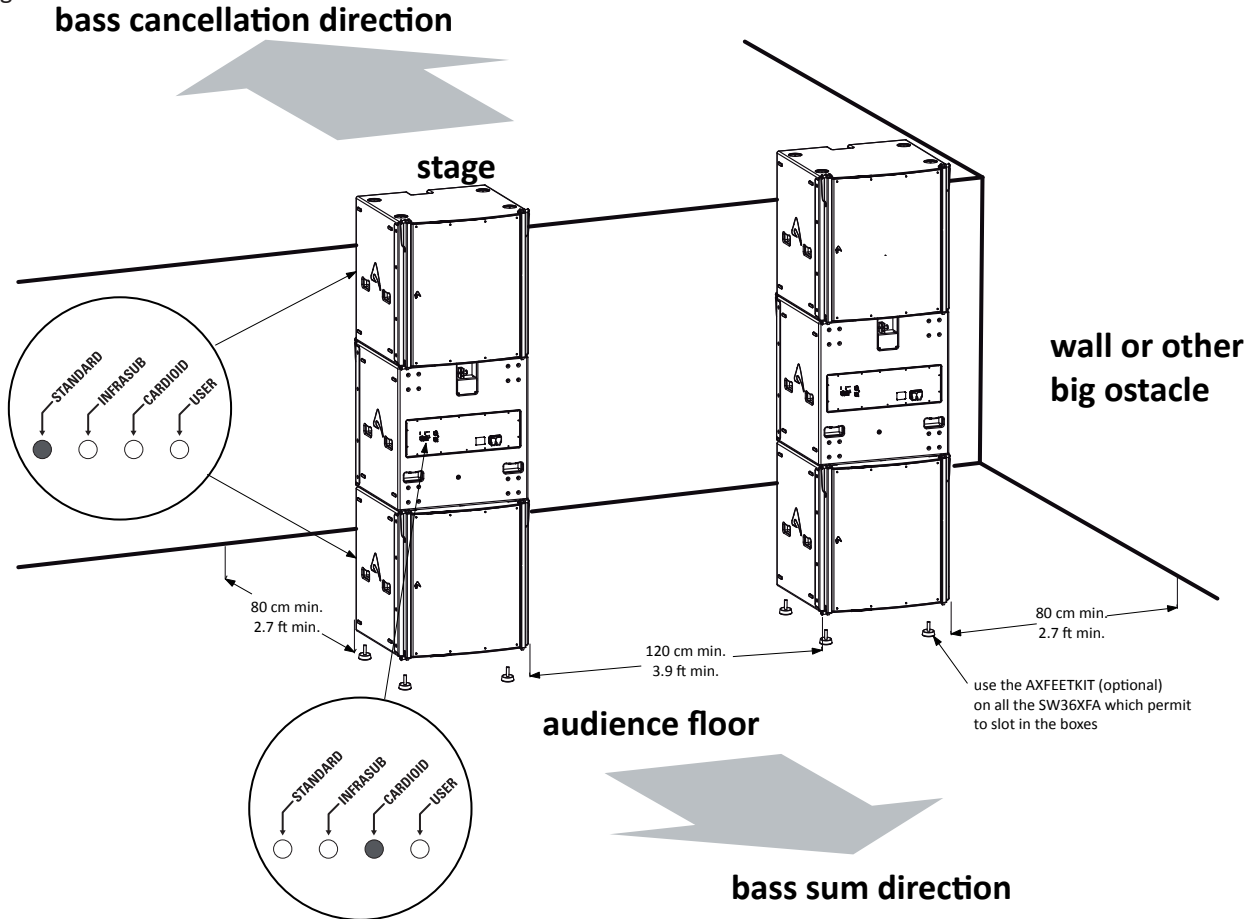

NOTES:

When placing the cardioid array keep a distance to walls or other obstacles of at least 80 cm (2.6 ft) in order not to affect the radiation of the reversed cabinet.

When placing multiple cardioid arrays keep a distance between them of at least 120 cm (3.9 ft) in order not to maximize the combined radiation of whole arrays.

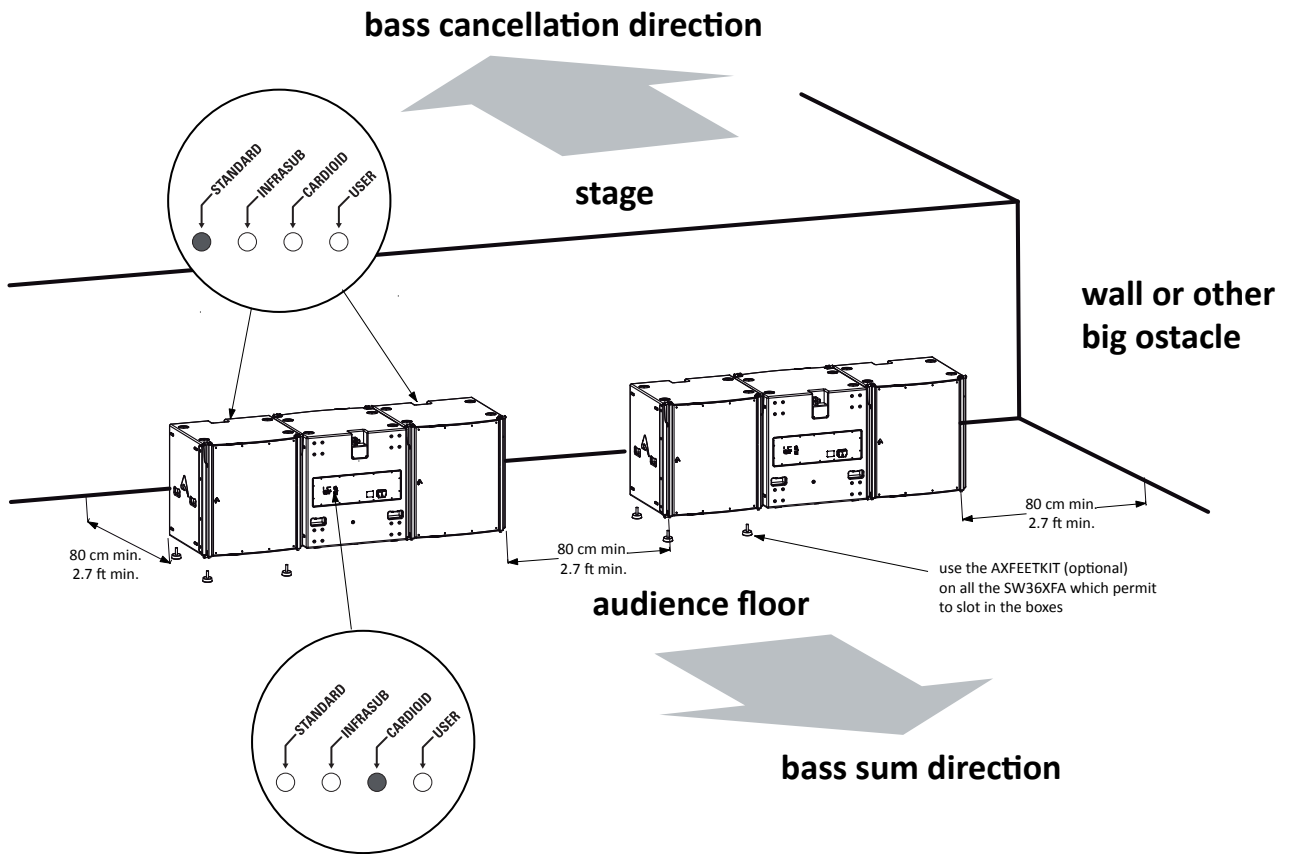

NOTES:
When placing the cardioid array keep a distance to walls or other obstacles of at least 80 cm (2.6 ft) in order not to affect the radiation of the reversed cabinet.
When placing multiple cardioid arrays keep a distance between them of at least 80 cm (2.6 ft) in order not to maximize the combined radiation of whole arrays.



PROEL S.p.A. (World Headquarters) - Via alla Ruenia 37/43 - 64027 Sant'Omero (Te) - ITALY
Tel: +39 0861 81241 Fax: +39 0861 887862 www.axiomproaudio.com

